



Macon Water Authority

Manual of  
Backflow Prevention and  
Cross-Connection Control  
And  
Emergency Response Program



Orig. 5/7/87  
Revised 11/12/03  
Revised 1/27/04  
Revised 3/10/04

Approved by the State of  
Georgia Environmental Protection Division  
3/15/04

# TABLE OF CONTENTS

## SECTION I

INTRODUCTION	4
SCOPE AND PURPOSE	4
DEFINITION OF CROSS CONNECTION	5

## SECTION II

WATER CUSTOMERS RESPONSIBILITY	5
--------------------------------	---

## SECTION III

BACKFLOW, CROSS CONNECTION & BACKFLOW PREVENTION DEVICES	6
THE BASICS OF BACKFLOW	6
TYPICAL CROSS CONNECTIONS	7
BACKFLOW PREVENTION DEVICES	8
REQUIREMENTS	8
APPROVAL OF DEVICES	9
DESCRIPTIONS	9
AIR GAP	9
DOUBLE CHECK VALVE ASSEMBLY	10
REDUCED PRESSURE ZONE ASSEMBLY	11
DOUBLE CHECK DETECTOR CHECK ASSEMBLY	12
DCDA FOR FIRE-SPRINKLER SYSTEMS	12
INSTALLATION AND LOCATION	13
TESTING	14
MANUFACTURERS OF APPROVED ASSEMBLIES	15

## SECTION IV

RISK GROUPS	16
POTENTIAL CROSS CONNECTIONS	16
RISK GROUP I	16
RISK GROUP II	19
RISK GROUP III	19

**SECTION V**

<b>CONTAINMENT PLAN</b>	<b>20</b>
<b>NEW CUSTOMERS</b>	<b>20</b>
<b>EXISTING CUSTOMERS</b>	<b>20</b>
<b>RISK GROUP I</b>	<b>21</b>
<b>RISK GROUP II, III</b>	<b>21</b>
<b>THERMAL EXPANSION</b>	<b>21</b>

**SECTION VI**

<b>IMPLEMENTATION OF PLAN</b>	<b>22</b>
-------------------------------	-----------

**SECTION VII**

<b>EMERGENCY PLAN</b>	<b>23</b>
<b>LABORATORIES</b>	<b>25</b>

**SECTION VIII**

<b>PUBLIC AWARENESS</b>	<b>26</b>
-------------------------	-----------

**SECTION IX**

<b>INVENTORY OF BACKFLOW PREVENTION DEVICES</b>	<b>26</b>
---	-----------

**SECTION X**

<b>ENFORCEMENT ACTIONS</b>	<b>26</b>
<b>APPENDIX A</b>	<b>27</b>

## SECTION I

### INTRODUCTION

#### SCOPE AND PURPOSE

The Georgia Environmental Protection Division (EPD) requires the Macon Water Authority to have a Backflow Prevention Program for the elimination and prevention of all *cross connections* to the public water system in accordance with The Georgia Rules for Safe Drinking Water, Chapter 391-3-5-13(4).

This program has the following purposes:

To administer a backflow prevention program by a policy of **containment** at the service connections.

To prevent and correct all potentially hazardous cross-connections and backflows to the Authority's system and from the possibility of degradation by "containing" within the customers premises any contamination or pollutants which could backflow or backsiphonage through the Authority's water service connections into the public water system.

To identify the policies and procedures for implementing and conducting a program of containment.

To identify the type of customers and relative risks of each customer for a potential cross connection.

To maintain a record of the customers, who have backflow protection devices and who are at risk of potential cross-connection.

To document a procedure for the isolation of portions of the distribution system in the event a backflow occurs and carries contamination into the system.

To assure that proper backflow protection devices are installed and maintained properly.

#### DEFINITION OF CROSS CONNECTION

A **cross connection** is an "unprotected" actual or potential connection or structural arrangement between a public or a consumer's potable water system and any other source or system through which it is possible to introduce into any part of the potable system any used water, industrial

fluid, non-potable fluid, non-potable water, gas, or substance other than the intended potable water with which the system is supplied.

In general, all cross connections represent a risk hazard to the potable water system. It may be considered as either a *low hazard risk* or a *high hazard risk*.

A **low hazard risk** is that which may introduce a *pollutant* into the potable water system.

A **high hazard risk** is that which may introduce a *contaminant* into the potable water system.

A **pollutant** is any foreign substance in water that tends to degrade its quality so as to constitute a non-health hazard or impair the usefulness of the water.

A **contaminant** is any foreign substance introduced into a water supply that degrades the quality and creates a health hazard.

A public hazard exists if there is any possibility and/or opportunity for a *backflow or backsiphonage* situation to occur through a cross connection.

Eliminating all cross connections is the best way to prevent the possibility of system contamination, caused by a backflow.

## **SECTION II**

### **WATER CUSTOMERS RESPONSIBILITY**

Commercial, industrial and water customer required to have a backflow prevention device (Risk Groups I, II, and III) shall be responsible for the installation, maintenance and testing of the backflow device or devices at his or her own expense. The following steps will be implemented when failure, refusal or inability on the part of the customer to install or test the said device(s):

1. 1<sup>st</sup> letter requiring installation and/or testing within 30 days of date on letter.
2. 2<sup>nd</sup> letter requiring written or verbal response within 15 days of date on letter.
3. 3<sup>rd</sup> letter requiring written or verbal response within 7 days of date on letter before subjected to a compliance charge of \$ 100 per day and/or termination of customer's water service.

All backflow prevention devices shall be tested annually, and a copy of the test result shall be mailed or faxed to the MWA, Backflow Prevention Coordinator's Office. @ 790 Second St. Macon, GA 31202, Fax number (478) 741-1239 or (478) 750-2007).

## **SECTION III**

### **BACKFLOWS, CROSS CONNECTION AND BACKFLOW PREVENTION DEVICES**

#### **THE BASICS OF BACKFLOW**

**Containment** is accomplished by placing a Backflow Prevention Device on the down stream side of the customer's meter, as close to customer's meter as possible, with no connections between the water meter and the Backflow Prevention Device.

The term **backflow** means the undesirable reversal of flow in a potable water distribution system as a result of a cross connection. A *backflow prevention device* (BFP) is just what the name implies. It is a device, or assembly, that prevents water, or any liquid, from flowing backwards or against the direction of which it was intended.

Backflow occurs due to one of two conditions being present at a cross connection. They are *backpressure* and *backsiphonage*.

**Backpressure** is a pressure, higher than the supply pressure, caused by a pump, elevated tank, boiler, air/steam pressure, or any other means, which may cause backflow.

**Backsiphonage** is caused by negative or reduced pressure in the supply piping.

Backflow prevention devices are designed to eliminate cross connections and backflow due to backpressure and/or backsiphonage. Some are designed for *high hazard risks*. Some are designed for only *low hazard risks*. Some are designed to eliminate all types of backflow, and some are designed to eliminate only some types of backflow. **When installing a backflow prevention device it is important to use the appropriate device for its designed application only.**

## TYPICAL CROSS CONNECTION

The following are examples of some typical cross connections, illustrating both backpressure and backsiphonage:

The most typical residential cross connection occurs when a homeowner uses an end-of-hose sprayer or drops a hose into a bucket to dilute a pesticide or herbicide.

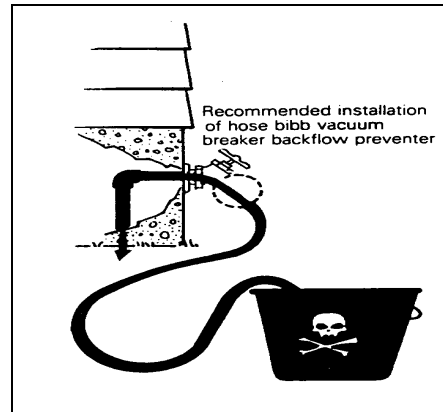
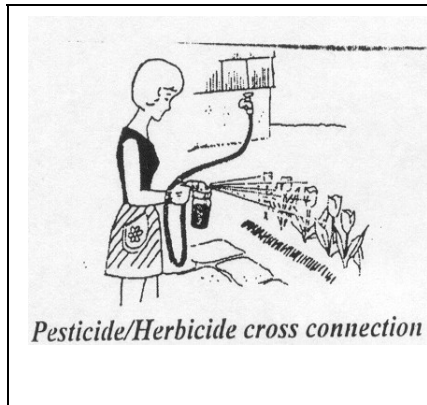

These

are examples of a cross connection that can cause system contamination if a “backsiphonage” should occur due to the existence of a negative pressure. Such pressure drops frequently occur when a nearby fire hydrant is opened or during a water main break. Although harmless in appearance and localized in effect, these cross connections may possibly result in serious illnesses and deaths.

The industrial equivalent of the example below is a tank, bath or sink that has a potable water inlet installed above the water surface to prevent splashing. That has been modified with the addition of a short section of hose which creates a submerged inlet. As with the first example, the development of a low-pressure area “up stream” can create a dangerous backflow situation due to “backsiphonage”.

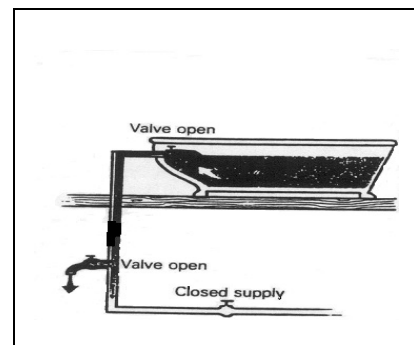
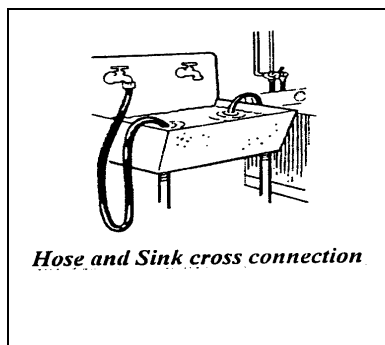

Occasionally it is desirable to have a submerged inlet and an overflow discharge. Examples include restaurant dish washing sinks, electroplating baths and swimming pools.

Another frequent cross connection involves an inline chemical feed system. Examples include chemical addition to boiler or cooling tower systems for corrosion or slime control, chemical or medication addition to livestock water supplies, and chemical additions at the municipal water treatment facilities. The latter of these cannot be avoided. Thus, extreme vigilant care must be exercised to prevent the overdosing of chlorine, fluoride, or other chemicals.

The final example of a cross connection to be given here is the connection of a municipal water system to a second water system of lower quality such as a well or lake. The most typical occurrence is an industry with both a well and a municipal water system connected to a sprinkler or boiler water system. The well pump could create a pressure higher than the municipal system. The “backpressure” could then force non-disinfected water into the municipalities potable water system.

## **BACKFLOW PREVENTION DEVICES**

### **REQUIREMENTS:**

Cross connections should be avoided, or eliminated, at all times. *Contaminants* and *pollutants* should never come in contact with the potable water system.

A cross connection can be effectively eliminated by the installation of an approved backflow prevention device.

The best method for elimination of a cross connection is the use of an **air gap**.

However, where an air gap is not possible, the influent line should be equipped with an approved *Double Check Valve Assembly* (DC) or a *Reduced Pressure Zone* (RP) backflow prevention assembly as specified in the International Plumbing Code 2003.

Generally, any cross connection that is deemed to be a *high hazard (Risk Group I)* must be protected by the installation of a RP except where a sufficient *air gap* has been provided. All other cross connections that are deemed to be a *low hazard (Risk Groups II, III)*, must have a DC installed downstream of the customers meter.

## APPROVAL OF DEVICES

The backflow preventors shall meet or exceed the requirements of the American Society of Sanitary Engineers (ASSE), American Water Works Association (AWWA), and or University of Southern California Foundation for Cross Control (USCFCC). (Macon Water Authority Standards for Design and Construction specifications for Water Distribution and Wastewater Collection, section 2.2, page 5.) See pages **14 & 15** of this manual for a list of approved manufactures of backflow prevention assemblies provided by the Georgia Department of Environmental Protection Division.

Ultimately, the Director or the Backflow Program Coordinator will issue final approval on acceptable backflow prevention devices.

## DESCRIPTIONS

### AIR GAP

For this discussion, the *air gap* is a physical separation between the free flowing discharge end of a potable water supply pipeline and an open or non-pressurized receiving vessel.

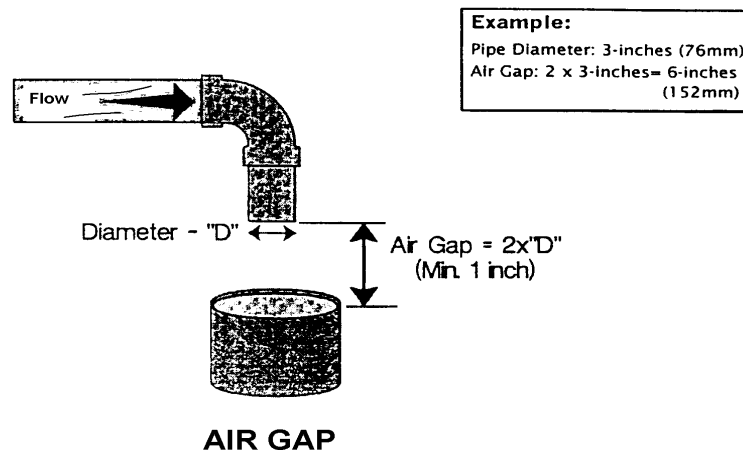

“An approved air gap is the unobstructed vertical distance through free atmosphere between the lowest point of a water supply outlet and the flood rim of the fixture or assembly into which the

outlet discharges. These vertical, physical separations must be at least twice the diameter of the water supply outlet, but never less than 1 in. (25 mm).” (AWWA M14, 4.2)

The air gap is the best form of backflow prevention available. It is acceptable for use under all hazard conditions and is the ONLY device approved for the backflow prevention of sewage and radioactive material.

## Double Check Valve Assembly

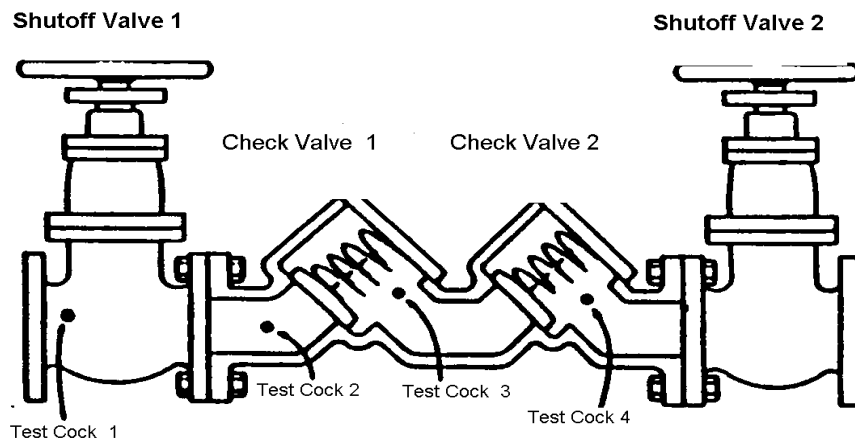

### DOUBLE CHECK VALVE ASSEMBLY

The **Double Check Valve Assembly (DC)** is composed of two independent acting, approved check valves, and including tightly closing resilient-seated shutoff valves located at each end of the assembly and fitting with properly located resilient-seated tests cocks. This assembly shall only be used to protect against a non-health hazard (that is, a pollutant).

The DC is the minimum backflow prevention requirement for all commercial, irrigation and industrial customers of the Macon Water Authority. Additional prevention may be required as indicated by the University of Southern California Manual of Cross Connection Control, Ninth Edition and/or the current Macon Water Authority Backflow Prevention and Cross Connection Control Manual.

## REDUCED PRESSURE ZONE BACKFLOW ASSEMBLY

The **Reduced Pressure Zone Assembly**, or the **RP**, as it is more frequently called, consists of two independently acting approved check valves together with a hydraulically operating, mechanically independent pressure differential relief valve located between two tightly closing resilient-seated shutoff valves as an assembly and are equipped with properly located resilient-seated tests cocks.

### Reduced Pressure Zone Assembly

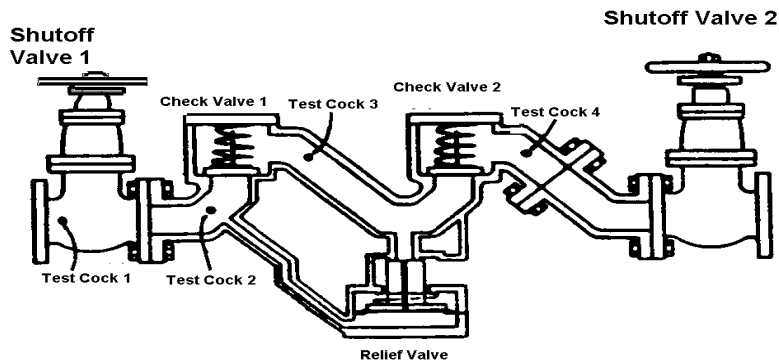

The RP is the second best backflow prevention device available. It is approved for all hazards EXCEPT sewage and radioactive material

## DOUBLE CHECK DETECTOR CHECK ASSEMBLY BACKFLOW PREVENTION ASSEMBLY

The term **Double Check Detector Check Assembly (DCDA)** refers to a specially designed assembly composed of a line-size approved double check valve assembly with a by pass containing a specific water meter and an approved double check valve assembly. The meter shall register accurately only very low rates of flow up to 3 g.p.m. and shall show a registration for all rates of flow.

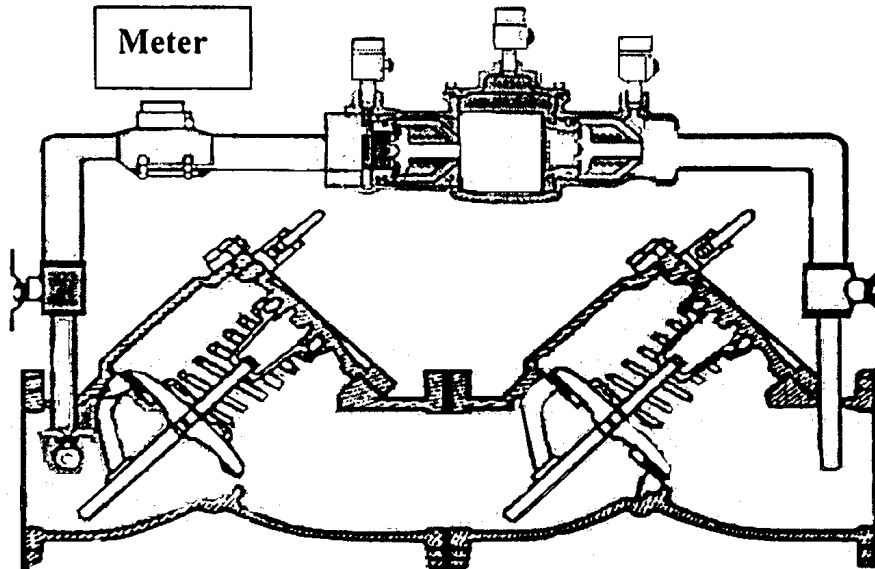

This assembly shall be used to protect against a non-health hazard (i.e., pollutant) and is composed of two independently acting, approved check valves, including tightly closing resilient-seated shutoff valves located at each end of the assembly and fitting with properly located resilient-seated test cocks health hazard (i.e., contaminant). **The DCDA is primarily used on low hazard fire-sprinkler systems.**

### “RPDA” FOR FIRE-SPRINKLER SYSTEMS

The Macon Water Authority does not make any engineering policies concerning the installation or maintenance of fire sprinkler systems. However, due to the various options available for systems, (i.e., sizes, sources, reserves, boosters and additives) it will be necessary to install a **Reduced Pressure Zone-Detector Backflow Assembly** on high hazard fire-sprinkler systems.

## **INSTALLATION AND LOCATION**

A Reduced Pressure Zone (**RP**) or a (**RPDA**) shall be installed in accordance with the following installation procedures, the Georgia State Plumbing Code, the manufacturer specifications and section 4.2 of the AWWA M14 second edition or latest edition.

An **RP** shall be installed with adequate space to facilitate maintenance and testing. Ideally, the installation should not require platforms, ladders, or lifts for access. The area shall be dry and free of electrical hazards.

**RP's** need to be protected from extreme heat and freezing temperatures. Consult manufacture's specifications for recommendations. An **RP** shall not be installed in a pit below ground level. Semi-buried pits are acceptable if the RP is installed above the ground or the maximum flood level with an approved air gap between the relief valve port and the daylight drain. If the relief valve port is submerged in groundwater, a cross connection is created that maybe more serious than the hazard that the assembly isolates.

**RP's** shall be located downstream of the service meter with no connections or tees between meter and backflow assembly. Directly behind the meter will be the required location for most devices.

If the **RP** is located inside a building, it is recommended that a drain be provided to receive spillage from the relief valve port. The relief valve port must always have an approved air gap between it and the drain or maximum flood level, whichever is highest.

An **RP** must be installed in a horizontal position, "in line" and at least 12" inches above ground or floor level.

A Double Check Valve (**DCV**) or a (**DCDA**) shall be installed in accordance with the following installation procedures, the Georgia State Plumbing Code, the manufacturer specifications and section 4.2 of the AWWA M14 second edition or latest edition.

A **DC** shall be installed with adequate space to facilitate maintenance and testing. Ideally, the installation should not require platforms, ladders, or lifts for access. The area shall be free from electrical hazards and one that provides a safe working environment for testing and maintenance.

DC's shall be installed in a box design to hold the device and provide adequate space for testing.

DC's shall be located downstream of the service meter with no connections or tees between meter and backflow assembly. Directly behind the meter will be the required location for most devices.

A DC must be installed "in line" and in a horizontal position unless designed differently by the manufacturer.

## **TESTING**

A Certified Backflow Prevention Assembly Tester must perform testing of all backflow prevention devices. Test procedures for all backflow prevention devices shall be as outlined in the **UNIVERSITY OF SOUTHERN CALIFORNIA: FCCCHR; MANUAL OF CROSS-CONNECTION CONTROL, SECTION 9. (SEE APPENDIX A)** A test and maintenance report for each device used in the containment concept shall be maintained by the consumer. Following each test, a report must be sent to the Backflow Coordinator for Macon Water Authority and must include the following: (a) Date of test and location (b) manufacture's name, model and serial number. (c) Name of certified tester and certificate number. (d) Test results (e) Description of repairs or servicing required (f) Date of repair. In addition to testing annually, testing must be done upon installation and after any repairs, modifications or upgrades.

## **MANUFACTURES OF APPROVED ASSEMBLIES**

The list of manufactures found below was provided by the Environmental Protection Division.

## Manufacturers of Approved Assemblies

Ames Company  
1485 Tanforan Avenue  
Woodland, CA. 05605  
916/666-2493

Arrowhead Brass  
5142 Alhambra Avenue  
Los Angeles, CA. 90032  
213/221-9137

Buckner, Inc.  
4381 N. Brawley Avenue  
Fresno, CA93722  
209/275-0500

Champion Brass Manufacturing Co.  
1460 N Nuad Street  
Los Angeles, CA 90012  
213/221-2108

Cla-Val Company  
P O Box 1325  
Newport Beach, CA 92659-0325  
714/722-4800

Conbraco Industries  
P O Box 247  
Matthews, NC 28105  
704/847-9191

Febco Division of CMB Industries  
P O Box 8070  
Fresno, CA. 93747  
209/252-0791

Flomatic  
P O Box 100  
North Hoosick, NY 12133-0100  
800/833-2040

Hardie Irrigation  
788 Fairview rive  
Carson City, NV 89701-5456

Hershey/Grinnell  
Research and Development Center  
1467 Elmwood Avenue  
Cranston, RI 02910

Kennedy Valve  
P O Box 931  
Elmira, NY 14902-0931  
6077/734-2211

Orion Industries  
613 N 5<sup>th</sup> Street  
Kansas City, KS 66110  
813/342-1653

Rain Bird Sales, Inc.  
145 North Grand Ave.  
Glendora, CA 91740  
818/963-9311

Strahman Valves, Inc.  
13 Vreeland Road  
Florham Park, NJ 07932  
201/377-4900

Toro Company  
5825 Jasmine Street  
Riverside, CA. 92504  
714/688-9221

Viking Corporation  
210 North Industrial Park Road  
Hastings, MI. 49058  
616/945-9501

Watts Regulator Company  
815 Chestnut Street  
North Andover, MA 01845  
508/688-1811

Wilkins Regulator Company  
1747 Commerce Way  
Paso Robles, CA. 93446

## SECTION IV

### RISK GROUPS

#### POTENTIAL CROSS CONNECTIONS

To be effective, the cross connection program must be enforced at specific industries, commercial and private establishments, and other miscellaneous buildings or locations where taps are made to the water system. To be efficient, the program must concentrate on businesses where the greatest probability of cross connection exists. The identification of the most likely source involves a review of the literature, case histories, and judgment of Macon Water Authority officials. The resulting list was divided into three risk categories or groups.

**Risk Group I** designates the water use sites considered most likely to have cross connection problems, or those firms which would create a serious health hazard if a backflow occurred. All customers who handle *contaminants* in their processes should be included in this group. These firms should be the first and principal concerns in the cross connection control program. This group requires an **Air Gap or a Reduced Pressure Zone Backflow Device**.

**Risk Group II** has the probability of creating a non-health hazard. The occurrence of a backflow at these firms would create a *pollutant* (taste and/or odor) problem rather than a health hazard, and hence is of secondary concern in program implementation. This group requires a **Double Check Valve Backflow Device or equal**.

**Risk Group III** has low risk of backflow and would create taste and odor problems. These firms should be inventoried by inspection after program adoption. This group requires a **Double Check Valve Backflow Device or equal**.

These Risk Groups relate to potential risks that are dependent upon internal processes, rather than the general category of the business or industry. The Engineering Department of the Macon Water Authority will make this determination. The following are compositions of each risk group and descriptions of the potential hazards:

#### Risk Group I

1. Food Processors and Food Related Industries (Bakery, Candy, etc.)
2. Textile Companies, Industrial Firms Subject to Wastewater Pretreatment Rules
3. Hospitals, Doctors and Dentist Offices and Other Medical Related Facilities
4. Nursing Homes - Assisted Living Homes – Orphanages (Children’s Homes)
5. Veterinary Hospitals
6. Funeral Homes
7. Laboratories (Chemical & Biomedical)
8. Sewage Plants
9. Water Plants
10. Pest Control & Lawn Care Companies
11. Dry Cleaning and Laundry Mat Facilities
12. College, Schools, and Apartment complexes
13. Airport Facilities
14. Brick Companies

15. Country Clubs
16. Car Washes
17. Chemicals - Handling, Manufacturing, Storage
18. Concrete & Concrete Products
19. Electrical Controls, Machinery
20. Furniture Manufacturers (Where contaminants are used)
21. Hotels, Motels, & Mobile Home Parks
22. Department Stores (where food services are provide on premises)
23. Multi-Story Buildings
24. Machine Shops, Metal Fabricators, Manufacturers (Water-Based Industries  
- YKK, Textprint, Riverwood, Brown & Williamson, etc.)
25. Recreation Parks & Fountains
26. Printing Companies - General News
27. Paper Products, Packaging, etc.
28. Gas and/or Service Stations
29. Ice Cream Manufacturers and Ice Manufacturers
30. Wells, ponds and other auxiliary water supplies.
31. Irrigation systems that inject chemical into sprinkler system

**Food Processing Companies**, including beverage bottling plants, may have cross connections occur in association with steam connected facilities; washers, cookers, tanks, lines and flumes; reservoirs, cooling towers, and circulating systems; industrial fluid systems and water-cooled equipment which may be sewer connected.

**Textile Industries** may contaminate public water lines as a result of *backsiphonage* from dye vats that use toxic chemicals and dyes. Other potential cross connections include shrinking, bluing and dyeing machines with direct connections to circulating systems or retention and mixing tanks outfitted with transfer pumps.

Several **industrial facilities**, not falling in a specific category, but which are subject to industrial wastewater pretreatment program rules, were included in this study, due to the nature of the materials they handle. These toxic materials could enter the public potable water system due to several sources:

1. Tanks, lines, valves, fittings, and other equipment such as pumps, rams and pressure cylinders being subjected to hydraulic tests;
- b) Hydraulically operated equipment where Macon Water Authority water system water pressure is indirectly used; or
- c) Conventional cross connection situations such as potable water inlets located below the fluid level in a tank.

In **hospitals**, cross connections may occur in contaminated or sewer connected equipment, such as bed pan washers, flush valve toilets and urinals, autoclaves, specimen tanks, sterilizers, pipette tube washers, cuspidors, aspirators, autopsy equipment and X-ray machines.

**Nursing Homes and Veterinary hospitals** have cross connection problems similar to those of a hospital because they both utilize a lot of the same type of equipment, but to a lesser extent.

**Funeral Homes and Laboratories** are most likely to incur a cross connection as a result of improper use of water-jet aspirators or other mortuary and laboratory equipment. Materials of concern in funeral homes include blood and embalming fluids. In the laboratory it is chemicals of almost every description.

At **Water Treatment Plants**, cross connections may occur in the process of addition of chemicals (especially compound feeders), scale and corrosion control, water filtration, water softening, and filter backwash systems.

**Pest Control Companies** are not likely to produce a cross connection, but due to the extreme toxicity to Macon Water Authority water system of the chemicals handled, they have been included on the list. The most likely cross connection is from the use of water operated spraying equipment. **Lawn-care companies** present a similar hazard through dealings with fertilizers and herbicides rather than pesticides.

**Laundries** having washing machines with under rim or bottom inlets may allow the *backsiphonage* of cleansing chemicals or dirt, grease and other pollutants into the public water system. Another potential cross connection is a wash water storage tank equipped with pumps and recirculating systems

Potential sources of cross connections at **Apartment Complexes, Schools and Colleges** include inadequately protected flush valve toilets, urinals, aspirators, retorts, and pipette tube washers, laboratory equipment which may be chemically or bacteriologically contaminated; steam generating facilities and lines; water-cooled equipment which is sewer connected; and irrigation systems. Large tanks and swimming pools may also present a hazard.

**Irrigation Systems** present a potential for cross connections, especially if equipped with pumps, injectors, pressurized tanks or vessels, or other facilities for injecting into the irrigation system agricultural chemicals, such as fungicides, pesticides and fertilizers. Irrigation systems are also subject to contamination from submerged inlets, auxiliary water supplies, ponds and reservoirs.

Any **building** containing **cooling towers** or **water tanks** is potentially subject to cross connection. A cross connection can occur when a potable water connection is made at or below the fluid level of the tank. The water pressure in the tank can cause *backpressure* in the water system. The towers and tanks may be contaminated with range of items from toxic water-treatment compounds; bacterial slime or algae, to bird droppings or vermin.

**Cold Storage Buildings** and plants have the potential of hazardous cross connections between the consumer's water system and: reservoirs, cooling towers, circulating systems, and steam generating facilities and lines; water-cooled equipment which may be sewer connected; and bottle washing machines and lines. The major *contaminants* of concern are the chemicals from water treatment and cleaning compounds

Water from a **well** or **pond** are required to have an air gap between water supplied by the Macon Water Authority.

## Risk Group II

1. Warehouses
2. Restaurants
3. Irrigation Systems (residential, commercial and industrial) without pumps injecting chemicals
4. Swimming Pools
5. Convenience Stores
6. Day Care Facilities
7. Department Store (where food services are **not provide** on premises)

**Irrigation Systems** present a potential for cross connections, especially if equipped with pumps, injectors, pressurized tanks or vessels, or other facilities for injecting into the irrigation system agricultural chemicals, such as fungicides, pesticides and fertilizers. Irrigation systems are also subject to contamination from submerged inlets, auxiliary water supplies, ponds and reservoirs.

**Restaurants** have several areas of operation susceptible to cross connections. Steam tables and dishwashing basins with submerged inlets may contaminate potable water lines with food products. Carbonation machines may carbonate outside potable water lines during a low-pressure event. Other miscellaneous restaurant equipment may also contribute to cross connection problems.

**Swimming pools** present hazards because water connections are often made below the water surface level. Cross connections may also occur in the chemical addition process.

### Risk Group III

Administrative buildings (1 story) offices i.e. lawyer, engineer, architect, insurance, travel agent, accountant & clerical.  
Electronic retail shops  
Gift shops

## **SECTION V**

### **CONTAINMENT PLAN**

#### **NEW CUSTOMERS**

All new commercial customers and customers changing a type of business at existing location shall submit a set of plans for review to the engineering department of the Macon Water Authority. The department will recommend the appropriate backflow prevention device for that business risk. Upon installation the backflow prevention device shall be tested and then tested annually thereafter. New customers shall abide by the rules and regulations stated in the Macon Water Authority's "Manual of Backflow Prevention and Cross-Connection Control and Emergency Response Program".

#### **EXISTING CUSTOMERS**

Existing commercial and industrial customers will receive a letter requesting the installation and or testing of a backflow prevention device for business address. Existing customers shall abide by the rules and regulations stated in the Macon Water Authority's "Manual of Backflow Prevention and Cross-Connection Control and Emergency Response Program".

##### Risk Group I

The use of an *air gap* or *reduced pressure zone (RP) assembly* on the service lines to the customer is mandatory. The customer will be responsible for installation and testing of these backflow prevention devices in accordance with standards set forth by the AWWA Manual-14 and this department. All backflow prevention devices shall be installed in accordance to the rules and regulations of the Macon Water Authority.

##### Risk Group II

A double check valve assembly or equal on the service line to the customer is mandatory. The requirements for selection, installation and testing are the same as in Risk Group I.

##### Risk Group III

The use of a double check valve assembly or equal on the service line to the customer is mandatory. The requirements for selection, installation and testing are the same as Risk Group I.

### **THERMAL EXPANSION**

*Thermal expansion* is the expansion of water due to being heated, as in a common water heater. This expansion causes water pressure to increase. In an unprotected or open water system, one

without a backflow prevention device, the additional pressures will *backflow* into the public potable water system. Closing the system with the addition of a backflow preventer will not allow this backflow to occur. Most water heaters are equipped with Pressure Relief Valves (PRV)'s to help stabilize the pressure caused by thermal expansion. In this situation **PRV's shall not be vented in such a way as to cause a cross connection**. It may be necessary for the customer to install an additional thermal expansion unit; one designed to relieve the added water pressure. Customers will be warned that the use of a backflow prevention device will result in a closed system and may cause some *thermal expansion* problems.

## **SECTION VI**

### **IMPLEMENTATION OF PLAN**

The Macon Water Authority's objective is to have backflow prevention devices tested at time of installation and annually thereafter. The water customer must have the backflow prevention assembly tested by a Certified Backflow Prevention Assembly Tester. The test results must be sent to the Backflow Prevention Coordinator of the Macon Water Authority. All test documentation will be recorded in the Backflow Prevention Program database.

**Key personnel** involved with the program are:

**Executive Director - *Mr. Tony Rojas***

**Field Operations Director – *Mr. Ray Shell*** - Director of the BFP Program

**Engineering Superintendent - *Mr. Michel Wanna*** - Manager of the BFP Program

**Engineering Supervisor- *Mrs. Lisa Golphin***- Oversees the Daily Operations of the Program

**Backflow Prevention Coordinator - *Mr. Rick Hayes*** – Manages the daily operations of the Backflow Prevention Program

**Backflow Prevention Program Member- *Mr. Kenyua Ellis***- Field verification of Devices

**Backflow and Cross Connection Inspector - *Mr. Reggie Cooper*** - Field Inspections

**Distribution/Sewer Conveyance Manager - *Mr. Darryl Macy*** -Isolation and Containment of Polluted and or Contaminated Water

**Distribution/Sewer Conveyance Assistant Manager - *Mr. Ricky NeSmith*** - Isolation and Containment of Polluted and or Contaminated Water.

**Director of Water Treatment- *Mr. Gary McCoy*** . – Director of Water Treatment Plant

**Assistant Manager of Water Treatment- *Ms. Jocelyn Hunt***. – Manager of Water Treat. Plant

**Laboratory Analyst II – *Ms. Sylvia McCrary*** - Schedules Sample Analysis and Testing

***Water Customers*** - responsible for having the installation of backflow prevention device and annual tests performed on backflow device(s). Copies of annual test reports must be sent to the Backflow Prevention Coordinator's Office at the Macon Water Authority.

## SECTION VII

### **EMERGENCY PLAN**

In the event of an emergency situation where contaminated or polluted water enters into the public water system, the Macon Water Authority mandates that the following actions be taken:

- A. Report of a Cross Connection to the MWA: **Business Hours (8am ~ 5pm) (478) 464-5620**  
**Or Engineering Office (8am ~ 5pm) (478) 464-5635**  
**After Hours (After 5pm) (478) 464-5656 or 464-5650**
- B. The following information will be obtained by the individual receiving the call or notification of the cross connection or chemical spill.
  - 1) Location of the emergency situation.
  - 2) Date and Time that the emergency situation occurred.
  - 3) Name of the person or company reporting the emergency situation.
  - 4) Type of potential contaminate(s).
  - 5) Physical form of contaminate(s). (Liquid, Solid, Gas, etc..)
- C. The following persons will be notified immediately upon notification of a cross connection or chemical spill: Executive Director, Field Operations Director, Distribution/Conveyance Manager, Distribution/Conveyance Assistant Manager, Water Treatment Director, Engineering Superintendent, Engineering Supervisor, Backflow Prevention Coordinator, Backflow Prevention Inspector, Lab Analyst II.
- D. An immediate evaluation of the cross connection or spill will be conducted and the following authorities will be notified of the situation. (EPD, Emergency Management Center, Police, Fire, Health Department, etc...) The contact person and phone number of each of these departments will be readily available to all key personnel involved within the program.
- E. The location of the emergency situation will be identified on a water system map to include all the appropriate valves that will be used to isolate and contain the problem area.
- F. A distribution service crew, a laboratory chemist/technician, the backflow team and/or Engineering Superintendent will be immediately dispatched to the emergency area upon notification.
- G. The Laboratory Chemist/Technician, Distribution/Conveyance Manager, and/or Engineering

Superintendent shall determine the limits of contamination upon evaluation of the emergency situation.

H. The Distribution Crew will isolate the contaminated area by closing all valves surrounding the problem area. They shall then flush and sanitize the contaminated lines back to the source of entry if possible. Sample collection and analysis will be then be performed again by the laboratory.

I. Notification and education to the General Public shall be issued through the following means:

- 1) Radio and television broadcasts as directed by the Macon Water Authority
- 2) Newspaper notices, as instructed by the Macon Water Authority
- 3) Door to door notification

The MWA Executive Director or his representative shall notify the Environmental Protection Division using the 24-hour emergency phone number.

**Emergency Contact Agencies**

<i>Environmental Protection Division</i>	~	<i>1-800-241-4113</i>
<i>Bibb County Fire Department</i>	~	<i>478-751-7370</i>
<i>Bibb County Police Department</i>	~	<i>478-751-7500</i>
<i>Emergency Management Center</i>	~	<i>478-751-7214</i>
<i>Bibb County Health Department</i>	~	<i>478-749-0121</i>

## LABORATORIES USE FOR TESTING

### **GA EPD Laboratory Operations Programs**

Atlanta, GA

Phone: 404 206-5269

David Jones, Laboratory Director

### **Analytical Services Inc**

Norcross, GA

770 734-4200

Lynn Collins, Project Manager

### **Environmental Health Laboratories**

South Bend, IN

(800) 332-4345

Laura Snell, Senior Project Manager

### **Macon Water Authority**

Mr. Gary McCoy, Director of Water Treatment

Office # (478) 464-5653

Cell # (478) 256-9407

[www.maconwater.org](http://www.maconwater.org)

## **SECTION VIII**

### **PUBLIC AWARENESS**

**The Macon Water Authority will encourage public awareness to the hazards of potential cross connections and to protect the public water system in the following way:**

1. Inspections and counseling with Risk Groups I, II and III
2. Educational mailers with the customers bills

## **SECTION IX**

### **INVENTORY OF BACKFLOW PREVENTION DEVICES**

The Macon Water Authority has an established program of filing test reports of new and existing backflow preventer. This program is administrated by the Macon Water Authority Backflow Prevention Coordinator.

## **SECTION X**

### **ENFORCEMENT**

The following enforcement actions may be taken on those users not complying with the Backflow Prevention and Cross Connection Control and Emergency Response Program.

- A. Inspections: Duly authorized employees of the Macon Water Authority bearing proper credentials and identification shall be permitted either alone or in the company of plumbing and health department officials to enter all properties for the purposes of inspection, observation, measurement and testing in accordance with the provisions of this policy.
- B. Warning: Any person found to be violating the provisions of this policy shall be served written notice stating the nature of the violation and shall be provided a reasonable time limit for the satisfactory correction thereof; except in cases of emergency where such notice would be improvident.
- C. Legal Action: Water service can be terminated and a reconnection fee will be charged and collected before the reconnection is made and/or a \$100 per day compliance charge will be imposed until corrective actions are taken on the part of the customer.

**See page 5, Section II, Water Customers Responsibility for timetable and charges associated with adherence to this policy.**

## APPENDIX A

### DOUBLE CHECK VALVE ASSEMBLY TESTING PROCEDURE (SINGLE HOUSE & TUBE METHOD)

#### PREPARATION

NOTIFY CUSTOMER  
IDENTIFY, INSPECT AND OBSERVE  
FLUSH TESTCOCKS  
INSTALL PROPER ADAPTERS AND FITTINGS  
INSPECT TEST KIT & CLOSE NEEDLE VALVES  
HAVE TUBES AVAILABLE, IF NEEDED

#### DEVICE SETUP

**INSTALL TEST GAGE AND HOSES AT SAME HEIGHT AS DEVICE**  
IF TEST COCK (TC) 3 IS NOT AT THE HIGHEST POINT OF THE CHECK VALVE BODY,  
INSTALL TUBE TO BRING WATER TO THE TOP OF THE BODY  
ATTACH HIGH SIDE HOSE & BLEED VALVE ARRANGEMENT TO TC2  
OPEN TC2 SLOWLY, THEN OPEN HIGH SIDE BLEED VALVE  
CLOSE HIGH SIDE BLEED VALVE  
IF TUBE IS ATTACHED, OPEN TC3 TO FILL TUBE, THEN CLOSE  
**RECORD LINE PRESSURE**  
CLOSE SHUTOFF VALVE #1  
OPEN TC3 (TC2 MUST BE OPEN, AND DISCHARGE OF TC3 MUST BE HIGHER THAN  
TC2 AND/OR CHECK VALVE HOUSING)

EVALUATE CV (CHECK VALVE) 1 IN DIRECTION OF FLOW  
**OBSERVE AND RECORD CV1 (PSI DIFFERENTIAL)**

#### EVALUATE CV 2 IN DIRECTION OF FLOW

CLOSE TC2 AND TC3  
OPEN SHUTOFF VALVE #1  
MOVE HIGH HOSE & BLEED VALVE ARRANGEMENT FROM TC2 TO TC3  
IF TC4 IS NOT AT THE HIGHEST POINT OF THE CHECK VALVE BODY, INSTALL TUBE  
TO BRING WATER TO THE TOP OF THE BODY  
OPEN TC3 SLOWLY  
OPEN HIGH SIDE BLEED VALVE, THEN CLOSE  
CLOSE SHUTOFF VALVE #1  
OPEN TC4 (TC3 MUST BE OPEN, AND DISCHARGE OF TC4 MUST BE HIGHER THAN  
TC3 AND/OR CHECK VALVE HOUSING)  
**OBSERVE AND RECORD CV2 (PSI DIFFERENTIAL)**  
**OBSERVE AND RECORD SHUTOFF #2 (LEAKS OR HOLDS TIGHT)**

#### COMPLETION

CLOSE ALL TESTCOCKS, DISCONNECT ALL HOSE, REMOVE FITTINGS  
AND DRAIN TEST KIT  
**OPEN SHUTOFF #1**  
**OPEN SHUTOFF #2 SLOWLY**

**REDUCE PRESSURE ASSEMBLY  
BACKFLOW PREVENTER TESTING PROCEDURE**

PREPARATION

NOTIFY CUSTOMER  
IDENTIFY, INSPECT, AND OBSERVE  
FLUSH TESTCOCKS: 4,3,2,1,4  
INSTALL PROPER ADAPTERS AND FITTINGS  
INSPECT TEST KIT & CLOSE ALL NEEDLE VALVES

DEVICE SETUP

ATTACH HIGH SIDE HOSE TO TC2  
ATTACH LOW SIDE HOSE TO TC3  
OPEN TC3, THEN OPEN LOW SIDE BLEED VALVE  
OPEN TC2 **SLOWLY**, THEN OPEN HIGH SIDE BLEED VALVE  
CLOSE HIGH SIDE BLEED VALVE  
AFTER GAGE REACHES UPPER END, CLOSE LOW SIDE BLEED VALVE  
**RECORD LINE PRESSURE**

OBSERVE CV1

CLOSE SHUTOFF VALVE #2  
**OBSERVE CV1 (CLOSED OR LEAKING): DO NOT RECORD APPARENT PRESSURE**

RELIEF VALVE OPENING POINT

OPEN HIGH SIDE CONTROL VALVE ONE FULL TURN  
OPEN LOW SIDE CONTROL VALVE SLOWLY ABOUT ¼ TURN  
**OBSERVE AND RECORD RV OPENING POINT(PSI DIFFERENTIAL)**  
CLOSE LOW SIDE CONTROL

CV2 LEAKAGE WITH BACKPRESSURE

OPEN BYPASS VALVE TO PURGE AIR  
ATTACH BYPASS CONTROL VALVE  
OPEN TC4  
REESTABLISH SETUP PRESSURE IN THE ZONE BY OPENING LOW SIDE BLEED VALVE, THEN CLOSE  
OPEN THE BYPASS CONTROL NEEDLE VALVE  
**OBSERVE AND RECORD CV2 (CLOSE TIGHT OR LEAKING WITH BACKPRESSURE)**

EVALUATE CV1 IN DIRECTION OF FLOW

REESTABLISH SETUP PRESSURE IN THE ZONE BY OPENING LOW SIDE BLEED VALVE, THEN CLOSE  
**OBSERVE AND RECORD CV2 (PSI DIFFERENTIAL)**

COMPLETION

CLOSE ALL TESTCOCKS, DISCONNECT ALL HOSES, REMOVE FITTINGS, AND DRAIN TEST KIT  
**OPEN SHUTOFF #2**